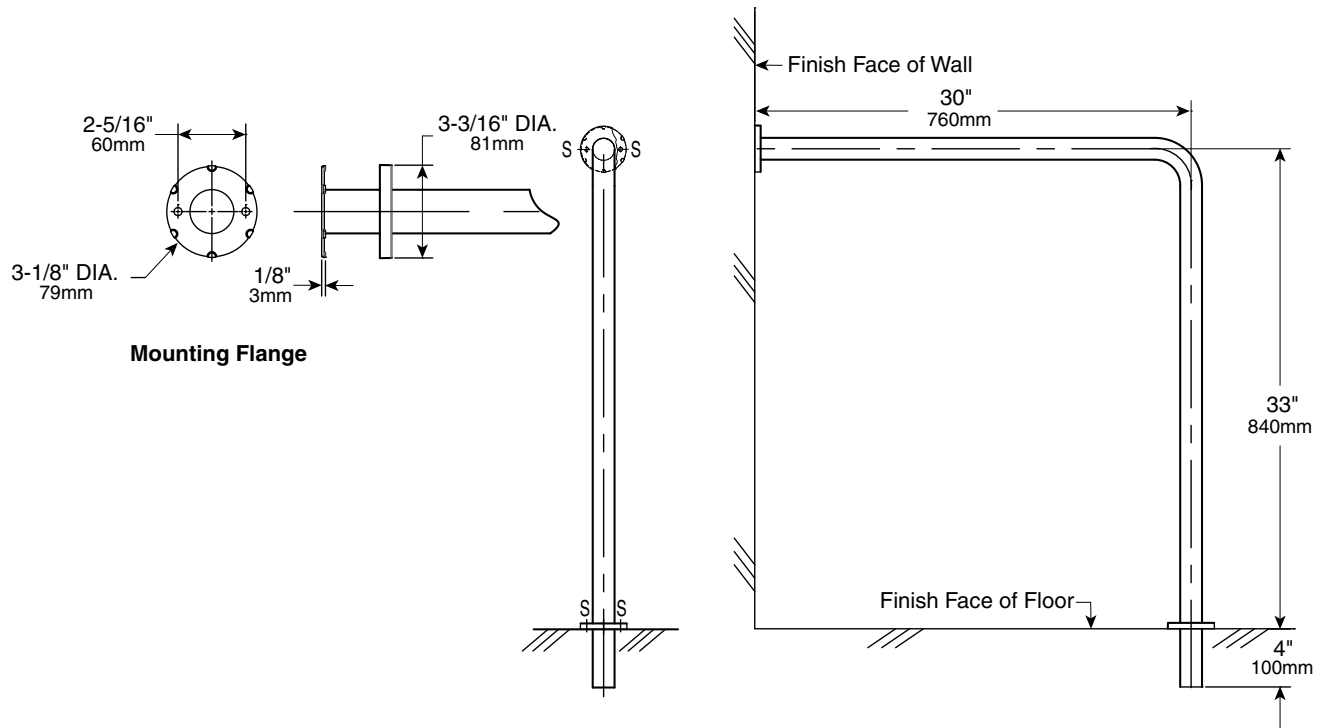

**BOBRICK****Technical Data****WALL TO FLOOR  
GRAB BAR  
WITH SOCKET END****819388****MATERIALS:**

**Grab Bar** – 18-8, type 304, 18-gauge (1.2mm) stainless steel tubing with satin-finish. 1-1/2" (38mm) outside diameter. Tubing is heliarc welded to mounting flanges.

**Concealed Mounting Flanges** – 18-8, type 304, 13-gauge (2.3mm) stainless steel plate, 3-1/8" (79mm) in diameter with 2 mounting holes for attachment to wall/floor; welded to tubing.

**Snap Flange Covers** – 18-8, type 304, 22-gauge (0.8mm) drawn stainless steel with satin-finish. 3-3/16" (81mm) diameter x 13/32" (10mm) deep. Each cover snaps over mounting flange to conceal mounting screws.

**STRENGTH:**

Grab bar can support loads in excess of 250 pounds (113kg) if properly installed, complying with accessible toilet compartment guidelines (including ADAAG in the U.S.A.) for structural strength.

**Safety Warning:** Grab bars are no stronger than the anchors and walls to which they are attached and, therefore, must be firmly secured in order to support the loads for which they are intended. To avoid potential injury, the building owner or maintenance personnel should remove the grab bar from service if the grab bar is not adequately secured to wall or if there is any observed damage to the welds.

**INSTALLATION:**

Provide concealed anchor device or backing as specified or required in accordance with local building codes before wall is finished. Pull snap flange covers away from mounting flanges. Drill a 1-1/2" x 4" (38 x 100mm) deep hole in finished concrete floor. Insert bottom end of grab bar in floor and use concealed mounting flange as a template to mark the locations of the two mounting screw holes on concrete floor. Remove grab bar and drill flange mounting holes in floor. Two 1/4"-20 x 2" (M6.3-1 x 51mm) stainless steel machine screws with metal expansion shields are recommended for floor installation. Embed bottom end of grab bar in floor and fasten concealed mounting flange to floor with mounting screws. Fasten concealed mounting flange at wall to anchor device or backing with two 1/4" or #14 (M6.3) sheet metal or wood screws. Snap flange covers over each mounting flange to conceal mounting screws. Concealed mounting screws and anchor devices are not included with this grab bar.

continued . . .

**Important notes:**

1. **Mounting Kits** — Bobrick offers a mounting kit for installing grab bars; **one Bobrick mounting kit is required for each flange.**

Mounting Kit No.	Description
252-30	Consists of (3) #14 x 2½" type-304 stainless steel, Phillips round-head, sheet-metal screws.

2. **Grab Bar Fastener** — Bobrick offers a grab bar fastening system that secures all Bobrick grab bar series; **one Bobrick fastener is required for each flange.** Install grab bar without backing in wall requires minimum 5/8" (16mm) thick painted or tiled drywall.

WingIt™ Fastener No.	Description
251-4	Consists of 10–32 x 5/16" round-head, Phillips 18/8 stainless steel screws. (1) WingIt grab bar fastener.

3. **Optional Anchor Device** — Bobrick grab bar anchor device includes stainless steel machine screws to be used for attaching grab bars to anchors. **one Bobrick concealed anchor device is required for each flange.**

Optional Anchor No.	Description
2583	Anchor for ¾" to 1" (19-25mm) panel 1 anchor required for each flange.
2586	Anchor for ½" to 1" (13mm) panel 1 anchor required for each flange.

**SPECIFICATIONS:**

Grab bar shall be type-304 stainless steel with satin-finish. Grab bar shall have 18-gauge (1.2mm) wall thickness and 1-1/2" (38mm) outside diameter. Concealed mounting flanges shall be 13-gauge (2.3mm) stainless steel plate, 3-1/8" (79mm) diameter, and equipped with two screw holes for attachment to wall and floor. Flange covers shall be 22-gauge (0.8mm), 3-3/16" (81mm) diameter x 13/32" (10mm) deep, and shall snap over mounting flange to conceal mounting screws. Grab bar tubing shall pass through concealed mounting flanges and be heliarc welded to form one structural unit. Grab bar shall comply with accessible toilet compartment guidelines (including ADAAG in the U.S.A.) for structural strength.

**Wall to Floor Grab Bar with Socket End shall be Model 819388 of Bobrick Washroom Equipment, Inc., Clifton Park, New York; Jackson, Tennessee; Los Angeles, California; Bobrick Washroom Equipment Company, Scarborough, Ontario; Bobrick Washroom Equipment Pty. Ltd., Australia; and Bobrick Washroom Equipment Limited, United Kingdom.**