

Model ZW221

One-Way Altitude Control Valve

Globe and Angle Valves

1 1/4", 1 1/2", 2", 2-1/2", 3", 4", 6", 8", 10", 12", 14" & 16"



☐ Installation ☐ Troubleshooting ☐ Maintenance Instructions

This valve controls the water level in an elevated reservoir by measuring the level change through a user installed sensing line. The main valve closes when water level reaches the high level set point. When the water level in the reservoir drops approximately 18-36", the valve reopens to fill the reservoir. The valve will not prevent reverse flow unless the check option is installed.

Installation / Start-up

NOTE: Flushing of all pipe lines is to be performed to remove all debris prior to installing valve.

1. Allow for adequate space around the valve for making adjustments and servicing before installing valve.
2. When installing a ZW221, shutoff valves installed on both inlet and outlet are recommended for maintenance allowing for isolation of valve.
3. Position the valve in line matching the direction of flow as indicated on the valve model tag with the proper direction of flow in the system. The flow arrow should point toward the reservoir. Once attached to line, double check all fasteners/bolts in the pilot system and on main valve are tight and there is no damage prior to pressurizing system.
4. Install a remote sensing line between the reservoir and the pilot sensing port reducer. The sensing line should be a minimum of 3/4" size and should not be connected the piping between the reservoir and valve as this may cause incorrect level readings. The sensing line should be copper, PVC pipe, or other corrosion resistant material. The line should slope up toward the reservoir to allow trapped or dissolved air to naturally vent and prevent inaccurate readings.
5. Zurn Wilkins valves are designed to operate in both the vertical and horizontal positions. However, it is recommended that ZW221 6" and larger, be installed in the horizontal position. The horizontal positioning of the larger valves avoids premature wear due to the mass of plunger assemblies as well as allows for greater accessibility during annual inspections, and maintenance.
6. The pilot drain line should be connected to safe drain location. If option F is ordered, then the accelerator pilot drain should also be connected to a safe drain.

Start-Up

1. Open the pilot ball valves (2) in the pilot system (see ZW221 Schematic).
2. Then slowly open the upstream supply shutoff valve only enough to fill main valve assembly and pilot system.
3. As the valve is filling with water, it is necessary to bleed the main valve and pilot system of air. To vent air, partially open or loosen the highest plugs or fittings in the system. Use caution when loosening plugs. Slightly open the test cock at the top of the ZPI valve position indicator with a screwdriver to vent air. It may be necessary to bleed system more than once. After removal of air in the system tighten all loose fittings. **NOTE:** If valve is installed vertically, it will be necessary to loosen some upper cover bolts until you have vented all the air from the cover chamber.
4. Vent the pilot sensing chamber by opening the sensing line isolation test cock, gauge isolation valve, and sensing chamber flush test cock. Once all air is removed, close the flush test cock.
5. Before setting pilot valve, if valve is equipped with speed controls (O or L on ZW221 schematic) it is necessary to back out the adjusting screw or handle a minimum of 3 turns from closed position. On larger valves the opening speed control is on the downstream line and the closing speed control is on the upstream supply side.
6. The sensing line isolation test cock and purge test cock can be used to check the pilot setting before opening downstream isolation valve. Check the reservoir level on the pilot sensing chamber gauge (reservoir isolation test cock and three way gauge isolation valve should still be open.) Close main valve cover pilot isolation valve. Loosen hose connection at cover isolation valve. Pressurized water will flow from this connection if the reservoir is above the pilot high setting. If no water flows, then the pilot is trying to fill the reservoir. To adjust the pilot, loosen jam nut on adjustment screw and either turn adjustment screw in to raise reservoir level or out to decrease reservoir level. See chart below. If pilot is set below reservoir level, slowly open sensing line isolation valve. As level rises on gauge, note high water reading on gauge when pilot drain discharges water. Adjust pilot to desired high level. After a few cycles of reservoir, verify pilot set point during reservoir filling, it can change slightly with reservoir fill rate and as air dissipates from system.

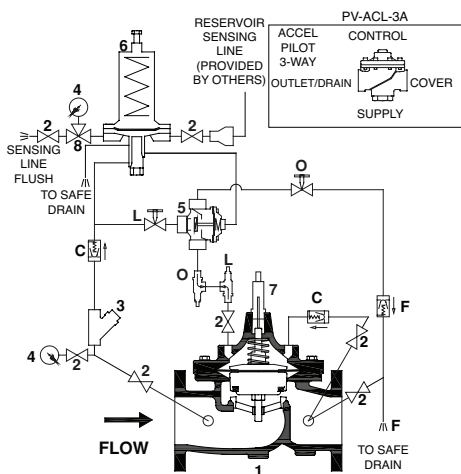

Schematic Diagram

Item	Description of Standard Features
1	Main Valve
2	850XL Isolation Valve
3	SXL "Wye" Type Strainer
4	Pressure Gauge
5	PV-ACL-3A Accelerator Pilot
6	PV-ALT Altitude Control Pilot
7	ZPI Position Indicator
8	3-Way Gauge Isolation/Sensing Line Flush Valve

PILOT	APPROXIMATE FEET PER TURN OF ADJUSTMENT BOLT
PV-ALT-33-55	1.25
PV-ALT-33-85	2.75
PV-ALT-33-230	5.0

7. Next it is advisable to flow water through the valve to ensure all air has escaped from system. High flow may be needed to flush all air. Fully open the upstream supply shutoff valve. Slowly open the downstream system shut off valve. Flow will begin to occur if the reservoir is not at the high level set by the pilot.

8. After pilot system has been adjusted and the valve is performing properly, the main valve opening and closing speed controls (O or L) can be adjusted as needed. Start with the speed controls three turns from fully closed. Unscrew stem to speed up the valve opening or closing.

9. Close three way gauge isolation valve and inlet pressure gauge isolation valve to prevent gauge damage. Leave sensing isolation valve (between pilot and sensing line reducer connection) open.

Troubleshooting

When the pilot valve senses the high water level has been reached, the diaphragm moves up allowing the plunger to close the supply pressure port and the main stem to vent the accelerator pilot cover to atmosphere through the drain port. The accelerator pilot then allows supply pressure to flow into the control valve cover to close the main valve. When water level drops in the reservoir, the drain port is closed by the main stem moving down and then the supply port is opened to allow water into the accelerator cover. The accelerator then vents the main valve cover to the downstream piping or to atmosphere, option F.

Table 1.

PROBLEM	POSSIBLE CAUSES	CORRECTIVE ACTION
1. Reservoir level too high	1. Pilot isolation valves closed 2. Sensing line has trapped air 3. Closing speed control shut or plugged 4. Pilot set too high 5. Sensing line plugged	1. Verify the inlet, outlet, cover, and sensing line isolation valves are open 2. (a) Purge sensing line of all air and sediment (b) Verify sensing line is sloped to prevent air being trapped at pilot 3. Verify speed control in correct position, exercise stem to remove any water deposits or debris 4. Lower setting by unscrewing adjustment bolt 5. (a) Check pilot valve for sediment build up under diaphragm (b) Verify sensing line isolation valves are open
2. Reservoir level too low	1. Supply pressure too low 2. Pilot isolation valves closed 3. Opening speed control shut or plugged 4. Pilot set too low 5. Sensing line plugged	1. Check valve inlet pressure gauge (and gauge isolation valve) to verify adequate supply pressure 2. Verify the inlet, outlet, cover, and sensing line isolation valves are open 3. Verify speed control in correct position, exercise stem to remove any water deposits or debris 4. Raise setting by screwing adjustment bolt in 5. (a) Check pilot valve for sediment build up under diaphragm (b) Verify sensing line isolation valves are open
3. Discharge from pilot bell weep hole	1. Leak in pilot diaphragm 2. Pilot diaphragm center bolt loose	1. Open and inspect diaphragm and bolt o-ring 2. Open and check that bolt is tight
4. Discharge from pilot drain	1. Normal operation 2. Worn o-rings 3. Corrosion/water deposits	1. (a) Drain tube drips and discharges water as reservoir reaches high level set point (b) Drain tube should be connected to a safe location where water can drain during valve operation 2. Disassemble pilot and check main stem o-rings 3. (a) Disassemble pilot and check small end of main stem, center chamfer should be smooth with no nicks or debris (b) Remove pilot main cap and plunger, inspect tip of plunger for corrosion or debris (c) Clean or replace parts as necessary

DIAGNOSIS CHECKS

CAUTION: Do not service valve while under pressure. When performing diagnosis checks on the ZW221 when the valve is fully open, high flow rates and high downstream pressures can occur. In order to prevent harm to personnel, equipment, and downstream piping be sure a downstream valve is closed before performing checks.

DIAPHRAGM CHECK

1. Slowly close upstream shut off valve and relieve all pressure downstream.
2. With all pressure relieved in the main valve, close both upstream and downstream pilot ball valves. Remove side plug

on cover and leave off.

3. Then open upstream shut off valve partially, allowing water to flow through the valve. While flowing water monitor the opening on the cover. Water will flow from the cover as the plunger assembly rises, if water continues to flow once fully open then there is most likely damage to the diaphragm or fluid is leaking past the diaphragm assembly due to loose assembly. It is recommended that the valve cover be removed to investigate the leakage (To remove cover see "Maintenance" section for procedures). If water stops flowing out of cover then the diaphragm is good and you may proceed to the diaphragm movement check.

DIAPHRAGM MOVEMENT CHECK

1. The diaphragm movement check can be determined during the diaphragm check by removing the top center plug or it can also be performed with the use of a valve position indicator model ZPI.
2. Replace cover plugs and open pilot ball valves on upstream and cover.
3. Closing the downstream pilot ball valves will direct the flow to the cover causing it to close. **NOTE: Slow or delayed closing of main valve is normal and is due to the time requirements to fill and pressurize cover, pushing the diaphragm into the closed position. This normal delay is not mechanical binding of the valve assembly.**
4. Using the valve position indicator, make note of the closed position on the indicator. Compare distance of the open mark to the close mark and compare to Table 3. (Or by measuring to the top of the stem under center plug before and after diaphragm check)
5. Verify that the main valve is closed, by opening a downstream source. If water continuously flows, then the main valve is not sealing properly. Double check the valve movement matches the values in Table 3 and refer to the disassembly procedures section if it does not. This is an indication that the main valve is not sealing due to an obstruction between the seat and the seal, stem or a damaged seal. If water does stop flowing and the measured valve movement does not match Table 3, then there is possible damage under the cover. Remove cover to identify obstruction and replace parts as necessary.

TABLE 3. VALVE STEM TRAVEL

VALVE SIZE (in)	VALVE SIZE (mm)	STEM TRAVEL (in)	STEM TRAVEL (mm)
1-1/4" - 1-1/2"	38	0.4	10.2
2"	50	0.7	18.0
2-1/2"	65	0.8	21.3
3"	80	0.9	23.4
4"	100	1.1	28.8
6"	150	1.7	43.4
8"	200	2.4	59.7
10"	250	2.8	71.1
12"	300	3.4	86.4
14"	390	3.8	96.5
16"	400	4.3	109.2

6. For smaller valves (6" and below) diaphragm checks can be performed by hand with the use of a valve stem tool. The valve stem tool can be made using Table 4 to create a "T" bar handle with the appropriate threads on the opposite end of the "T" handle.

TABLE 4. VALVE STEM THREAD SIZE

VALVE SIZE (in)	THREAD SIZE UNF INTERNAL
1-1/4" - 1-1/2"	10-32
2"	10 - 32
2-1/2"	10 - 32
3"	1/4 - 20
4"	1/4 - 20
6"	1/4 - 20
8"	3/8 -16
10"	3/8-16
12"	3/8-16
14"	3/8-16
16"	3/8-16

7. To perform the diaphragm check using the valve stem tool, first remove all pressure in the system and vent the cover. Then remove the center plug on the cover and insert tool into the top of the stem threads. Once the tool is inserted, the valve can be lifted up and the valve movement can be measured by creating marks on the tool in the opened and closed positions. The distance between marks is the valve stem travel. Replace or repair any parts as necessary. **Caution:** water will squirt from center hole or can be vented from extra plug on cover when lifting.

SEAL RING CHECK

1. To check the seal of the valve disc, an additional pressure gauge will be needed downstream of main valve. Also isolate low flow bypass line if equipped.
2. With the valve flowing, slowly, close downstream pilot ball valves to apply pressure to cover and allow to close.
3. Open downstream source to relieve all downstream pressure and then completely close downstream shutoff valve or downstream source to close downstream system. Monitor the pressure on the inlet and installed outlet gauge, for one min. The pressure on the outlet side should remain zero. If the pressure matches inlet pressure or increases, the main valve is leaking or the outlet ball valve on the pilot system is allowing pressure to creep by. Either way it is recommended that the valve be disassembled and inspected (refer to "Disassembly" section).

Maintenance Instructions

PREVENTATIVE MAINTENANCE

The Zurn Wilkins ZW200 models require minimal maintenance. However, it is highly recommended to schedule annual inspections and to have a repair kit on hand before work begins. Valves used often may be inspected on an annual basis, but at least every five years. Valves that rarely open, should be inspected every six months to one year for water deposits, debris, or corrosion.

DISASSEMBLY

Warning: Because of the ability to perform inspections and maintenance without removal from the system, it is very important that all shut off valves be closed and all pressure relieved in the valve before beginning disassembly. Failure to do so can result in personnel injury or equipment damage.

1. Verify that all pressure sources are closed up and downstream of valve.
2. Remove pressure in pilot system by loosening the tube fittings to the valve body and cover. When all pressure has been vented, continue to disassemble the pilot control valve and cover tubing. **NOTE:** Taking a picture before tear down can help with re-assembly of pilot system.
3. Next remove the cover by loosening and removing the cover bolts. If the cover does not come off easily it may be necessary to loosen the cover using a brass chisel and rubber mallet. Apply the chisel under the cover pointing upward away from valve body and tap bottom of cover with the chisel and mallet to loosen the cover. Once the cover is loose, pull cover straight up to avoid damaging the stem and stem bearing in the cover. On larger valves 8" and up, eye bolts and a hoist are recommended due to the weight of these larger covers.

4. With the cover removed the diaphragm assembly can be removed. To avoid damaging the seat bushing, grab the stem and lift straight up. For larger valves 8" and up it is recommended that an eye bolt with the proper stem threads be used with a hoist to lift the assembly out of the valve (see Table 4 for appropriate stem threads).
5. Next it is recommended that the diaphragm assembly be placed in a vise with the bottom hex secured. Once secured remove the spring and stem nut.
6. After inspecting the stem and removing the nut the diaphragm assembly can be dismantled. If the valve has not been serviced in awhile it is possible that the assembly will require the use of a rubber mallet or pry bars to dismantle the assembly. If this is the case gently tap or pry the components until the components are free to move. When disassembling be sure to clean, inspect, and save all components. Replace any damaged components as necessary.
7. The last component to inspect is the seat which is in the body of the main valve. During inspection of the seat, clean and polish as necessary with fine grit wet/dry sandpaper (400 grit or higher). Typically, if after cleaning there is no visual damage or excessive wear the seat should not require removal. If damage is present or the seat is excessively worn the seat should be replaced.
8. To remove the seat, on valves 6" and smaller the seat is threaded into the body and will require a seat removal tool. Care should be taken when removing the seat to avoid damaging. On 8" and larger valves, the seat is held in place with flat head hex screws. For larger valves a seat puller may be required to remove the seat from the body. A seat tool may be made by grinding three notches for the spokes in the end of a pipe. Turn with a pipe wrench.

INSPECTION OF COMPONENTS

Cleaning of components is required for proper inspection. Lime deposits are common in systems that use water. To remove deposits, fine grit wet/dry sandpaper (400 grit or higher) can be used. If deposits cannot be removed, off the shelf lime deposit remover can be used. Prepare a solution following the lime deposit remover instructions and soak components (excluding rubber components) until lime deposits are removed.

CAUTION: When handling chemicals (acids) be sure to use proper safety equipment (gloves and eye protection) and practices. After soaking components, be sure to thoroughly rinse all components before handling and re-assembling valve.

Once all valve components have been cleaned, inspect each component looking for damage, abnormal wear & corrosion, and replace all components that look questionable. Replace all rubber components including the diaphragm, o-rings and disc each time the valve is serviced or inspected (rubber components are standard in ZW200 repair kits).

REASSEMBLY

1. First reinstall seat into body. Be sure to use lube around seat o-ring before tightening. Tighten seat according to torque values in Table 5 using seat tool.
2. Next place valve stem in a vise clamping on the hex portion of the stem. Then assemble the diaphragm assembly as shown in Figure. When assembling be sure that the diaphragm is centered on the raised step of the disc retainer. It is also recommended to apply lube to stem threads and o-rings before tightening. Then tighten the stem nut according to Table 5 for torque values.
3. Lower diaphragm assembly carefully into the seat bushing. Be careful not to damage the seat or stem while installing assembly. Rotate the assembly as needed until the bolt holes on the diaphragm line up with the body bolt holes.
4. Place lower spring disc on the diaphragm disc and place spring on top of the assembly. Then install cover, aligning the bolt holes and insuring that the cover is not pinching the diaphragm between the bolt holes. Position cover so plug holes and pilot connection are in original position.
5. Install cover bolts and tighten in a star pattern to the torque values in Table 5.
6. Before installing center cover plug manually check that assembly has full operating travel before installing the pilot assembly (refer to "Diaphragm Movement" in the diagnosis checks section).
7. Once full operation range of the main valve is verified, begin reinstalling pilot system.
8. After installing pilot system double check that all plugs, bolts, and fittings are sealed and tight before applying pressure.
9. Slowly open upstream supply isolation valve to pressurize the system and check for any leaks.
10. Stop leaks as needed and proceed to "Start-Up" and "Diagnosis Check" sections for returning valve to proper system operations.

TABLE 5. VALVE TORQUE SETTINGS

VALVE SIZE (in)	COVER (ft-lbs)	DIAPHRAGM ASSEMBLY (ft-lbs)	THREADED SEAT (ft-lbs)	SEAT BOLTS (ft-lbs)
1-1/4"	3.5	7.5	11	N/A
1-1/2"	3.5	7.5	11	N/A
2"	15	20-25	30	N/A
2-1/2"	25	25-35	60	N/A
3"	25	35-45	70	N/A
4"	55	40-50	85	N/A
6"	110	50-60	95	N/A
8"	120	60-70	N/A	7.4
10"	184	70-75	N/A	7.4
12"	200	110-115	N/A	7.4
14"	275	170-175	N/A	7.4
16"	360	230-240	N/A	7.4

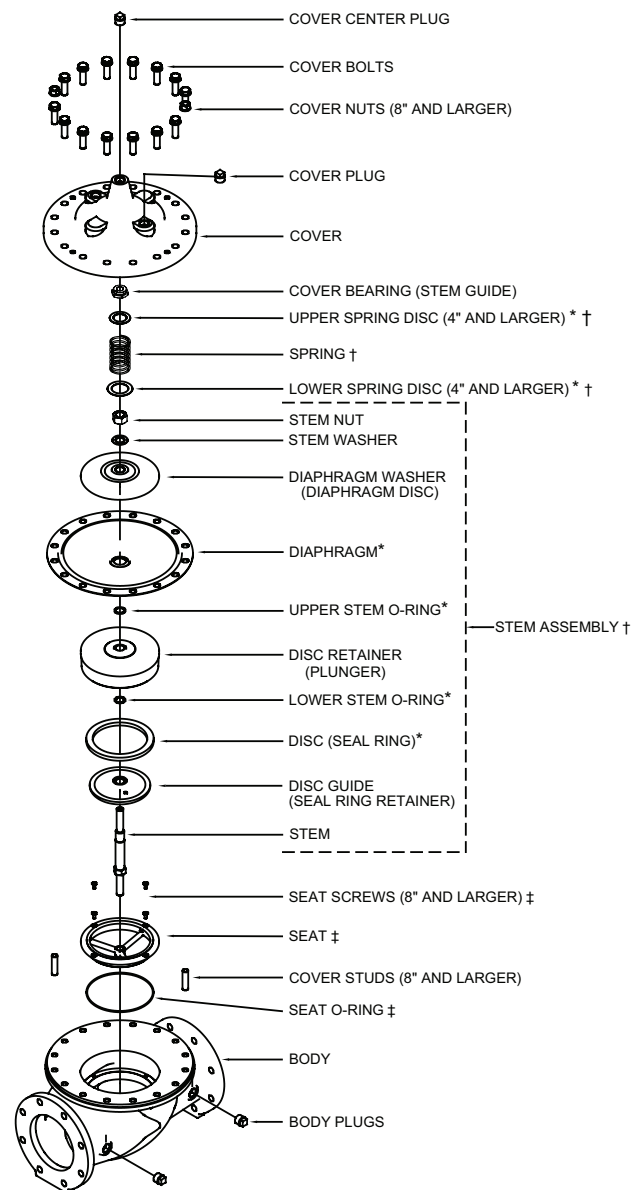

- * RUBBER REPAIR KIT ITEMS
- † COMPLETE REPAIR KIT ITEMS
- ‡ SEAT REPAIR KIT

Flow Characteristics

BODY MINIMUM FRICTION LOSS

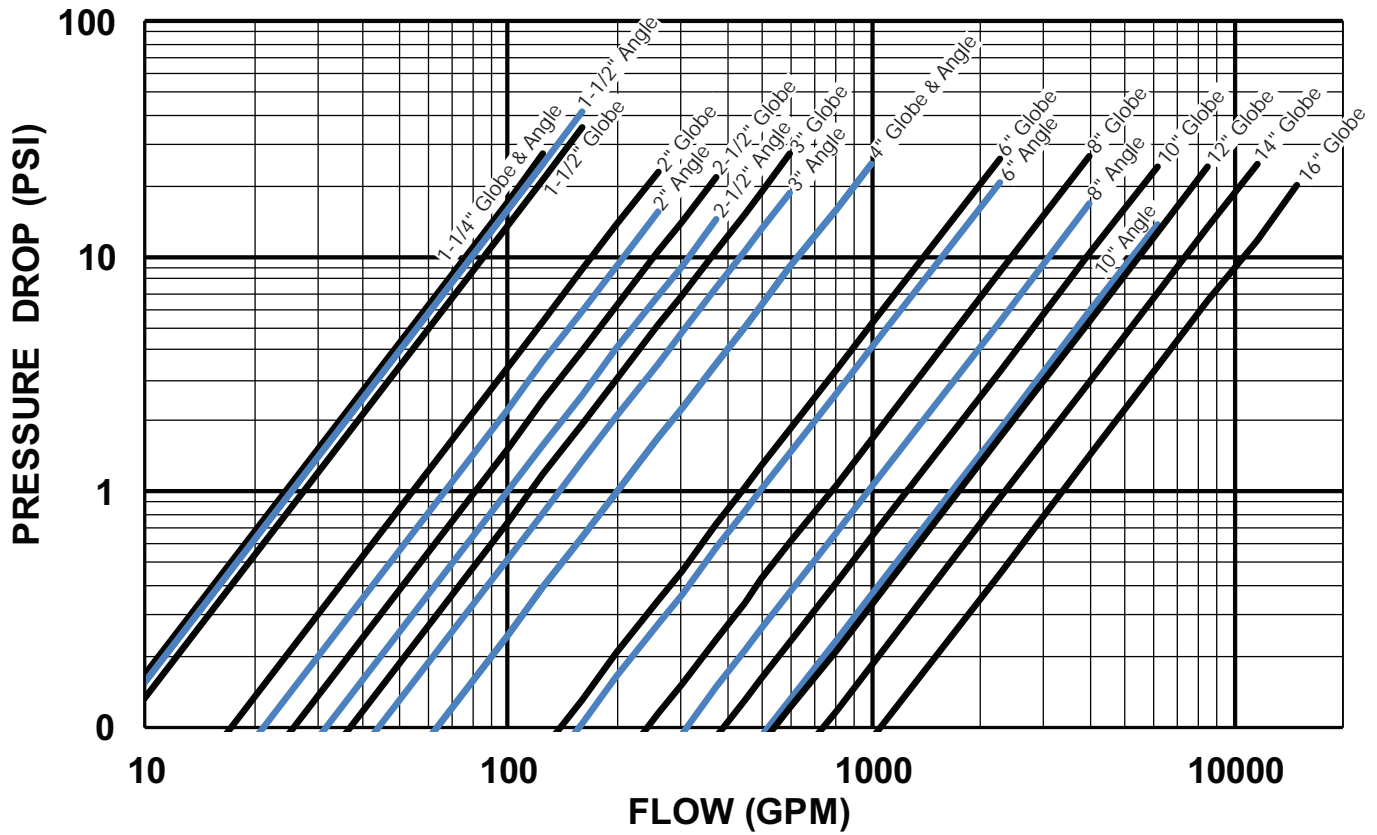

WARNING: This product may contain a chemical(s) known to the State of California to cause cancer or birth defects or other reproductive harm

ADVERTENCIA: Este producto puede contener un químico conocido en el estado de California por causar cáncer o defectos de nacimiento u otros daños reproductivos

Model PV-ACL-3A

3-Way Accelerator Pilot



- Maintenance Instructions
 Installation
 Troubleshooting

Maintenance Instructions

The 3-Way Accelerator Pilot may be installed in any position. The valve ports are labeled below.

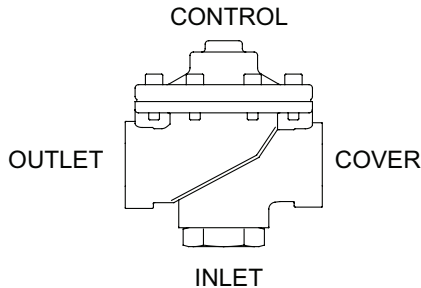

DISASSEMBLY

Prior to disassembly, relieve all pressure in pilot system and then remove the PV-ACL-3A. Note the pilot connections and reinstall the pilot with the same connection placement when finished with maintenance.

- Secure valve body and remove bottom seat on bottom of valve using an adjustable wrench.
- Next remove 8 socket head screws around the pilot bell using a 5/32" hex key.
- Remove the pilot bell.
- Use a 5/32" hex key for the bottom plunger screw and a 12mm socket or adjustable wrench on the diaphragm nut to disassemble the plunger/diaphragm assembly. Unscrew one end of the stem.
- At this point slide the plunger/diaphragm assembly out of the valve body, and remove the spring.
- Use soft jaws or a towel and pliers to clamp the stem. Remove the plunger, screw, and small o-ring from the plunger assembly and 2 large washers, diaphragm, lock washer, o-ring and nut from the diaphragm assembly.
- After complete disassembly, thoroughly clean and inspect all components before reassembly. Replace any parts as necessary after inspection.
- The pilot seat generally does not need to be removed, but if after inspection it requires replacement it can be removed with a 1-1/16" socket.

PV-ACL-3A VALVE REASSEMBLY

Reassembly of the PV-ACL-3A is the reverse of disassembly.

- Install one of the large washers (with round edge toward the diaphragm), the new o-ring, and the diaphragm followed by the second large washer (with round edge toward the diaphragm). Then place lock washer over stem threads along with the 5/16" diaphragm nut and tighten.

- Place spring on stem and slide stem assembly into body through pilot seat.
- Place small o-ring in plunger hole then slide the plunger onto the stem via the bottom seat hole followed by the cap screw. While holding diaphragm nut, tighten the cap screw with Allen wrench.
- Install bottom seat in bottom of valve body with new o-ring.
- Install pilot bell on the valve body, with tag in correct location
- Insert socket head cap screws into pilot bell holes and thread into valve body. Tighten all screws in a cross pattern.
- Reinstall into the pilot system once maintenance is completed. For further assistance or ordering replacement parts go to www.zurn.com or call product support 877-222-5356.

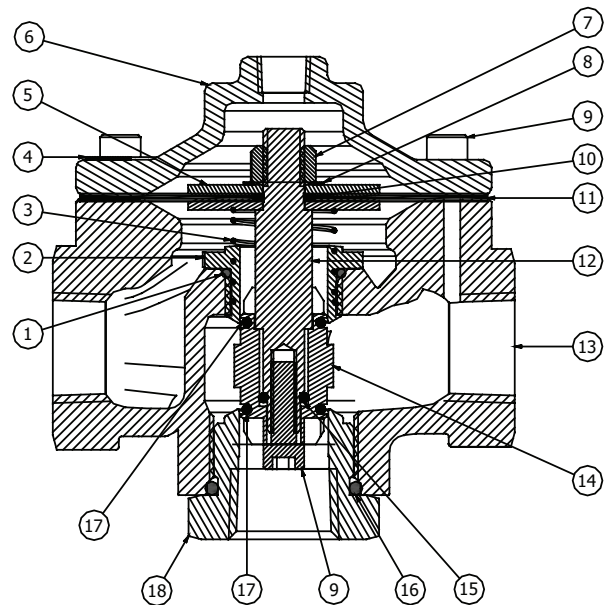

ITEM	DESCRIPTION	ITEM	DESCRIPTION
1	O-RING	10	DIAPHRAGM O-RING
2	PILOT SEAT	11	DIAPHRAGM
3	ACL STEM SPRING	12	ACL STEM
4	TAG, ACCELERATOR PILOT	13	BODY
5	DIAPHRAGM WASHER	14	ACL PLUNGER ASSY.
6	ACL BELL	15	STEM O-RING
7	5/16-18 DIAPHRAGM NUT	16	O-RING, BUNA-N
8	5/16" INT TEETH LOCKWASHER	17	PLUNGER O-RINGS
9	10-32x5/8 SKT HEAD CAP SCREW	18	ACL MAIN CAP/SEAT

PV-ACL-3A SPECS:

Max Inlet Pressure: 400 psi



Model PV-ALT

Altitude Level Control Pilot



- Maintenance Instructions Installation Troubleshooting

Maintenance Instructions

The PV-ALT may be installed in any position. At low water level, the large level adjustment spring forces the diaphragm and main stem down. This connects the lower supply port to the middle cover port and shuts off the drain port. At high water level, the reservoir pressure forces the diaphragm up. This shuts off the supply port and connects the cover port to the drain port. There are two connected ports just below the middle flange of the valve. These connect to the reservoir level sensing chamber. One connection goes to the reservoir, the other leads to the reservoir level gauge, isolation valve and flush valve.

DISASSEMBLY

Prior to disassembly, relieve all pressure in the pilot system and in the reservoir sensing line.

1. Note the height of the adjusting bolt. This will be used after assembly to set the pilot back to same reservoir level.
2. Disconnect pilot lines attaching to altitude pilot and accelerator pilot.
3. Secure the valve. Loosen the adjustment lock nut, and unscrew the adjusting bolt until it can be turned by hand and the spring load has been removed.
4. Next remove the 8 spring bell bolts. Note two longer bolts go to the rear to hold the pilot to its mounting bracket.
5. Lift the spring bell off slowly and make sure not to drop the main spring, upper and lower spring discs, and spring guide tube if present.
6. Remove the diaphragm assembly.
7. Lift the main stem, washer, and return spring from the cavity in the body. The nut on the main stem is sealed with loctite and does not need to be removed for repair.
8. Unscrew and remove the stem guide bushing, being careful not to lose the stem o-ring contained in the bottom of the bushing.
9. Using a small pick lift out the stem spacer and lower stem o-ring.
10. On the bottom of the valve body, remove the lower plunger cap, plunger spring, and plunger. The last two items are loose and may fall out.
11. The pilot seat threads in the bottom of the body using a 1/2" deep socket and loctite. It should be replaced if the main stem and plunger are being replaced. The plunger seals against the seat and main stem with lapped surfaces and should be replaced as a set.
12. Disassemble, clean and inspect all parts including the stem passage in the body. Remove any water deposits. Replace components as necessary.

PV-ALT VALVE REASSEMBLY

1. Install the plunger seat with loctite if it was removed.
2. Lightly grease main cap o-ring and slide over cap threads. Place plunger into seat, then plunger spring and thread main cap into body.
3. Lightly grease the two stem o-rings. Drop one down into stem passage in the body followed by the stem spacer, small end first.
4. Insert one of the greased stem o-rings into the end of the stem bushing. Grease and slide the bushing o-ring over the threads of the bushing. Thread the bushing into the body.
5. Place the stem return spring onto the bushing. Slide the stem washer up the stem to the nut. Slightly grease the stem and slide the stem down into the bushing. Once against the return spring, push the stem down till it hits the bushing. Make sure the stem travels down completely and returns on its own freely without any binding.
6. Place the lower diaphragm washer onto the diaphragm bolt with the sharp edge toward the bolt head.
7. Place the diaphragm onto the bolt, followed by the diaphragm o-ring. Place the large diaphragm disc onto the bolt smooth side toward the diaphragm. Tighten the diaphragm assembly nut.
8. Place the diaphragm assembly, bolt head down, onto the valve body. Center the diaphragm edge inside the lip of the body.
9. Put a small amount of grease into the dimple in the two spring discs. Place the lower spring disc onto the diaphragm bolt. Center the spring onto the raise bump of the lower disc. Add the upper spring disc onto the top of the spring. On the 55 foot and 85 foot models, add the spring guide tube over the spring. While holding and guiding the spring, lower the spring bell onto the body. Make sure the small weep hole at the base of the bell is forward so any leakage is visible.
10. Place the long two bolts into the back holes of the bell. Place the six other bolts into the bell. Make sure the diaphragm is not pinched and tighten all the bolts evenly in a cross pattern.
11. Screw the adjustment bolt back down to the dimension that was measured and tighten the locknut.
12. Attach the pilot to the main valve body and bracket. Reconnect all the hoses and tubes. Slowly pressurize and check for leaks. Follow the startup procedure for the main valve. For further assistance or ordering replacement parts go to www.zurn.com or call product support 877-222-5356.



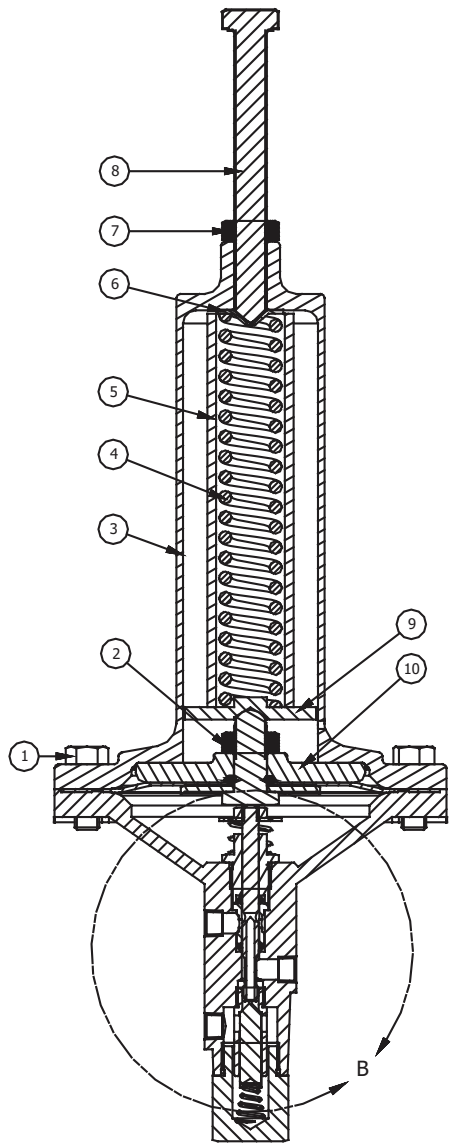

SECTION A-A
SCALE .8

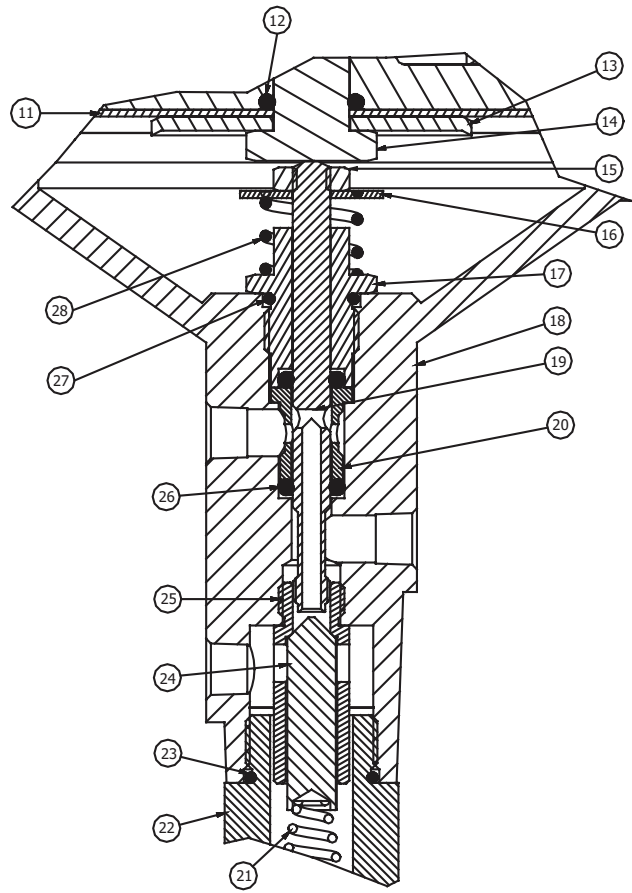

DETAIL B
SCALE 2 : 1

ITEM	DESCRIPTION
1	BOLT
2	DIAPHRAGM NUT
3	SPRING BELL
4	MAIN SPRING
5	SPRING GUIDE (-55 AND -85 ONLY)
6	UPPER SPRING DISC
7	JAM NUT

ITEM	DESCRIPTION
8	ADJUSTING BOLT
9	LOWER SPRING DISC
10	UPPER DIAPHRAGM DISC
11	DIAPHRAGM
12	DIAPHRAGM O-RING
13	LOWER DIAPHRAGM WASHER
14	DIAPHRAGM BOLT

ITEM	DESCRIPTION
15	STEM NUT
16	STEM WASHER
17	STEM GUIDE BUSHING
18	BODY
19	STEM SPACER
20	PLUNGER SPRING
21	MAIN CAP

ITEM	DESCRIPTION
22	CAP O-RING
23	PLUNGER
24	SEAT
25	MAIN STEM
26	STEM O-RING
27	BUSHING O-RING
28	STEM RETURN SPRING

NOTICE: Annual inspection and maintenance is required of all plumbing system components. To ensure proper performance and maximum life, this product must be subject to regular inspection, testing and cleaning.

WARRANTY: ZURN WILKINS Valves are guaranteed against defects of material or workmanship when used for the services recommended. If in any recommended service, a defect develops due to material or workmanship, and the device is returned, freight prepaid, to ZURN WILKINS within 12 months from date of purchase, it will be repaired or replaced free of charge. ZURN WILKINS' liability shall be limited to our agreement to repair or replace the valve only.

WARNING: This product may contain a chemical(s) known to the State of California to cause cancer or birth defects or other reproductive harm
ADVERTENCIA: Este producto puede contener un químico conocido en el estado de California por causar cáncer o defectos de nacimiento u otros daños reproductivos