

Model 38-PV-PRD

Pressure Reducing Valve (3/8")



- Maintenance Instructions
 Installation
 Troubleshooting

Maintenance Instructions

The PV-PRD Pressure Reducing Valve may be installed in any position. There is one inlet port and two outlets, for either straight or angled installation. A flow arrow is marked on the body and should be oriented as needed.

DISASSEMBLY

Prior to disassembly, relieve all pressure from the valve and then remove the PV-PRD.

1. Secure valve body and remove main cap on bottom of valve using an adjustable wrench.
2. Use a 13 mm socket to remove the plunger.
3. Next remove adjustment cover (plastic cover), 3/8" adjustment bolt with nut, 8 socket head screws around the pilot bell using a 5/32" hex key, spring, and spring disc.
4. At this point the PRV stem yoke is free to move and can be removed from the valve body.
5. Continue to remove the 5/16" diaphragm nut, lock washer, and diaphragm retainer.
6. After completely disassembling, thoroughly clean and inspect all components before reassembly. Replace any parts as necessary after inspection.
7. The pilot seat generally does not need to be removed, but it can be removed with a 1/2" socket, if required.

2. Next carefully slide yoke assembly into body and around pilot seat.

NOTE: Line up diaphragm screw holes with holes in body. Move yoke up and down checking for yoke contacting or dragging on valve body.

3. Then attach plunger to the bottom of the pilot yoke via the main cap hole and tighten with a 13 mm socket.
4. Install main cap in bottom of valve body with new o-ring.
5. Install spring, spring disc, and pilot bell on the valve body.
6. Insert socket head cap screws into pilot bell holes and thread into valve body. Tighten all screws in a cross pattern.
7. Install adjusting screw by hand with jam nut. Set valve once reinstalled into pipe system.
8. For further assistance or ordering replacement parts go to www.zurn.com or call product support 877-222-5356.

REASSEMBLY

Reassembly of the PV-PRD is the reverse of disassembly.

1. Install the new o-ring on top of pilot yoke threads followed by new diaphragm and diaphragm disc. Then place lock washer over pilot yoke stem along with the 5/16" diaphragm nut and tighten. Diaphragm bolt holes must be centered on yoke legs. See following diagram:

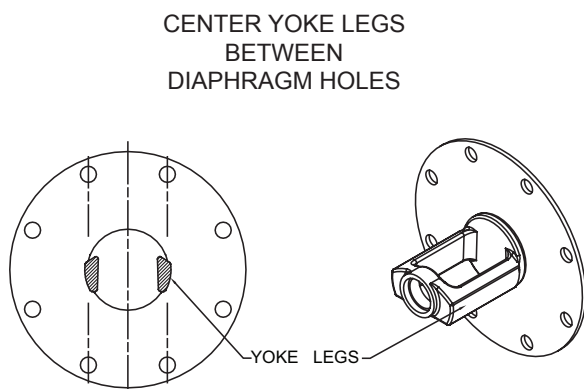
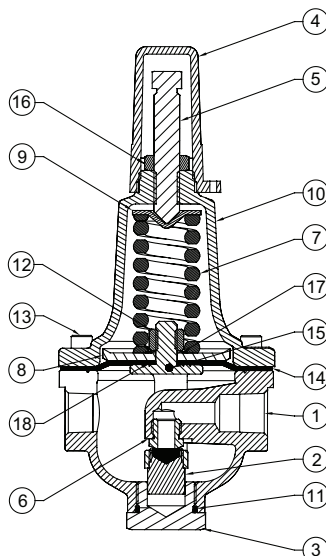

TABLE 1

| ITEM | DESCRIPTION |
|------|---|
| 1 | 3/8" PRV-PILOT BODY, LEAD FREE BRASS |
| 2 | PLUNGER, SS W/BUNA NITRILE 90 SHORE |
| 3 | MAIN CAP, LEAD FREE BRASS |
| 4 | ADJUSTMENT COVER |
| 5 | 3/8"-16 ADJUSTMENT BOLT, BRASS |
| 6 | 3/8" PILOT SEAT, SS |
| 7 | 20-200 PSI SPRING, CHROME SILICON |
| 8 | DIAPHRAGM DISC, SS |
| 9 | SPRING DISC, SS |
| 10 | PILOT BELL, BRASS |
| 11 | O-RING, BUNA NITRILE NSF LISTED |
| 12 | 5/16"-18 DIAPHRAGM NUT, SS |
| 13 | 10-32X5/8 SOCKET HEAD CAP SCREW |
| 14 | DIAPHRAGM NYLON REINFORCED BUNA NITRILE |
| 15 | PRV STEM YOKE, SS |
| 16 | 3/8"-16 JAM HEX NUT, SS |
| 17 | 5/16" INTERNAL TOOTH LOCK WASHER, SS |
| 18 | O-RING, BUNA NITRILE NSF LISTED |
| 19 | UL TAG RED, BRASS |



PV-PRD SPECS:

Adjustment Range Pressure: 20-200 psi
(Flowing residual outlet pressure)
Max Inlet Pressure: 400 psi

Installation Instructions

Before installing the pressure reducing valve, flush out the line to remove loose dirt and scale which might damage the plunger and seat. Install the valve in line with the arrow on the valve body pointing in the direction of flow. All valves will be furnished with stock settings. To readjust reduced pressure, loosen the outer locknut and turn the adjustment bolt clockwise (into the bell housing) to raise the reduced pressure, or counterclockwise (out of the bell housing) to lower the reduced pressure. The valve may be installed in a horizontal or vertical position.

Troubleshooting

| <u>PROBLEM</u> | <u>POSSIBLE CAUSES</u> | <u>CORRECTIVE ACTION</u> |
|--|---|---|
| 1. Outlet pressure is above set pressure | <ol style="list-style-type: none">1. The spring is over compressed2. Foreign matter obstruction3. Cut, worn or chipped plunger seal or seat.4. Damaged diaphragm or stem o-ring5. Yoke dragging on body | <ol style="list-style-type: none">1. Loosen the adjusting screw2. Disassemble and remove obstruction, replace parts as necessary3. Replace with new plunger or seat.4. Disassemble and replace diaphragm or o-ring5. Disassemble valve. Check yoke placement per Reassembly Step 2 and reassemble |
| 2. Outlet pressure is below set pressure | <ol style="list-style-type: none">1. Weak or no spring compression2. Spring damaged3. Spring disc out of place4. Yoke dragging on body5. Foreign matter between plunger and main cap | <ol style="list-style-type: none">1. Turn adjusting screw in to increase pressure regulation2. Disassemble and replace spring as needed3. Disassemble and replace or adjust spring disc as needed4. Disassemble valve. Check yoke placement per Reassembly Step 2 and reassemble5. Disassemble and remove obstruction |
| 3. Leakage from valve | <ol style="list-style-type: none">1. Damaged diaphragm, yoke or main cap o-ring2. Ports not sealed3. Loose diaphragm nut | <ol style="list-style-type: none">1. Disassemble and replace damaged part as needed2. Remove and reinstall port fittings Teflon tape or pipe sealant3. Disassemble and re-tighten the diaphragm nut |

NOTICE: Annual inspection and maintenance is required of all plumbing system components. To ensure proper performance and maximum life, this product must be subject to regular inspection, testing and cleaning.

WARRANTY: ZURN WILKINS Valves are guaranteed against defects of material or workmanship when used for the services recommended. If in any recommended service, a defect develops due to material or workmanship, and the device is returned, freight prepaid, to ZURN WILKINS within 12 months from date of purchase, it will be repaired or replaced free of charge. ZURN WILKINS' liability shall be limited to our agreement to repair or replace the valve only.

WARNING: This product contains a chemical known to the State of California to cause cancer, birth defects and other reproductive harm

ADVERTENCIA: Este producto contiene una sustancia química que el Estado de California como causante de cáncer, defectos de nacimiento y otros daños reproductivos



1747 Commerce Way, Paso Robles, CA 93446 Phone:855-663-9876 Fax:805-238-5766

ZURN WILKINS

2