

Application

The Zurn Wilkins Model ZW207 Excess Pressure Shutdown Valve is designed for many applications where protection of downstream components from high pressure is required. The ZW207 will quickly close to protect downstream components from high pressure when upstream pressure rises above the set pressure of the pilot valve. The Excess Pressure Shutdown Valve will close when inlet pressure rises because of damage, failure, or fouling to an upstream pressure reducing valve, a quick closing valve downstream, or a sudden upstream pressure surge. When the upstream pressure is below the set point of the pilot assembly, the main valve will remain fully open. In addition the Model ZW207 comes standard with epoxy coating internally and externally for corrosion protection, as well as isolation valves and an outlet pressure gauge for quick and easy maintenance or repair.

Standards Compliance:

- ANSI/AWWA C530
- Meets the requirements of NSF/ANSI 61*
*(0.25% MAX. WEIGHTED AVERAGE LEAD CONTENT)

Materials

Main Valve Body	Ductile Iron ASTM A536
Main Valve Bonnet	Ductile Iron ASTM A536
Disc Guide	Stainless Steel
Seat	Stainless Steel
Disc	Buna-N Rubber
Diaphragm	Nylon Reinforced Buna-N
Stem	Stainless Steel
Spring	Stainless Steel

Standard Features

- Blue Epoxy Coated, FDA Approved
- Pilot Assembly
 - "Wye" Type Strainer
 - Isolation Valves
- Inlet Pressure Gauge
- ANSI Class 150 Flanges
- Copper Tubing and Brass Fittings

BODY CONFIGURATIONS		GLOBE STYLE BODY		ANGLE STYLE BODY
END CONNECTION	PRESSURE RATING	FULL PORT	REDUCED PORT	
Threaded	400 psi max.	1 1/4"-3"	n/a	1 1/4"-3"
Flanged	ANSI Class 150, 250 psi max.	1 1/2"-16"	3"-10"	1 1/2"-10"
	ANSI Class 300, 400 psi max.			
Grooved	300 psi max.	1 1/2"-10"	n/a	1 1/2"-10"

MINIMUM INLET PRESSURE 10 PSI

Schematic Diagram

Item	Description of Standard Features
1	Main Valve
2	850XL Isolation Valve
3	SXL "Wye" Type Strainer
4	Pressure Gauge
5	Restriction Fitting
6	PV-RLF Pilot Valve



- Temperature Rating: Water 33°F to 140°F
- Pilot Spring Range: 50-200 psi

Options

(Add suffix letters to ZW207)

Function

- C - 40XL2 Hydraulic Check with Isolation Valve Body

- A - Angle Style Body
- R - Reduced Port Body

Connections

- G - IPS Grooved
- TH - NPT Threaded
- Y - ANSI Class 300 Flanges

Main Valve Options

- V - Viton Rubber Internals, rated 180°F (1-1/4"-6")
- Z - ZPI Visual Position Indicator

Pilot System

- LP3 - 5-15 psi Low Pressure Range PV-RLF Pilot
- LP2 - 10-35 psi Low Pressure Range PV-RLF Pilot
- LP - 30-90 psi Low Pressure Range PV-RLF Pilot
- HP - 150-300 psi High Pressure Range PV-RLF Pilot
- SP - All Stainless Steel Pilotry (replaces all brass fittings, pilot valve and copper tubing. "GL" Option included)
- SH - Stainless Steel Braided Hoses (only replaces Copper Tubing)
- RV - Pilot on Reverse Side
- GL - Liquid Filled Gauge

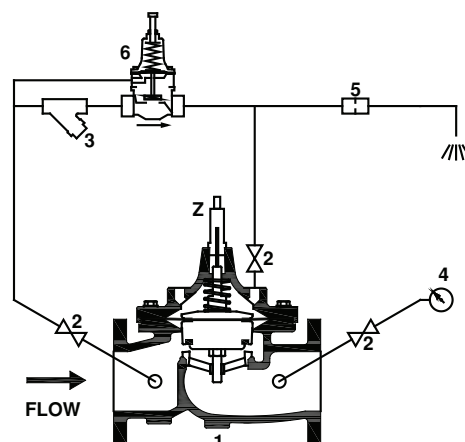

Globe and Angle Main Valve Dimensions

DIM	FULL PORT	VALVE SIZE INCHES (mm)											
		1 1/4 (32)	1 1/2(38)	2 (50)	2 1/2 (65)	3 (80)	4 (100)	6 (150)	8 (200)	10 (250)	12 (300)	14 (350)	16 (400)
A	Threaded	7 1/4	7 1/4	9 7/16	11	12 1/2							
	Class 150 Flange		8 1/2	9 3/8	11	12	15	20	25 3/8	29 3/4	34	39	41 3/8
	Class 300 Flange		9	10	11 5/8	13 1/4	15 5/8	21	26 7/16	31 1/8	35 1/2	40 1/2	43 1/2
	Grooved		8 1/2	9	11	12 1/2	15	20	25 3/8	29 3/4			
B	Diameter	5 5/8	5 5/8	6 3/4	8	9 3/16	11 11/16	15 3/4	20 1/8	23 11/16	27 1/2	31 3/4	34 1/2
C	Max.	5 3/4	5 3/4	6 3/16	7 3/8	8	10 3/16	12 5/16	15 9/16	17 5/8	20 3/16	22 13/16	25 7/8
D	Threaded/Grooved	1 3/8	1 3/8	1 3/4	2 1/8	2 9/16	3 7/16	5	5	5 13/16	6 3/4	8 7/8	8 13/16
	Class 150 Flange		2 1/2	3	3 1/2	3 3/4	4 1/2	5 1/2	6 3/4	8	9 1/2	10 1/2	11 3/4
	Class 300 Flange		3	3 1/4	3 3/4	4 1/8	5	6 1/4	7 1/2	8 3/4	10 1/4	11 1/2	12 3/4
E	NPT Body Tap	3/8	3/8	3/8	1/2	1/2	3/4	3/4	1	1	1	1	1
F	NPT Cvr. Plug Tap	1/2	1/2	1/2	1/2	1/2	3/4	3/4	1	1	1	1	1
G	NPT Cover Tap	3/8	3/8	3/8	1/2	1/2	3/4	3/4	1	1	1	1	1
H	Threaded	3 1/4	3 1/4	4 3/4	5 1/2	6 1/4							
	Class 150 Flange		4	4 3/4	5 1/2	6	7 1/2	10	12 11/16	14 7/8			
	Class 300 Flange		4 1/4	5	6	6 7/16	8	10 1/2	13 1/4	15 9/16			
	Grooved		4 7/16	4 3/4	5 1/2	6	7 1/2	10	12 11/16	14 7/8			
J	Threaded	1 15/16	1 15/16	3 1/4	4	4 1/2							
	Class 150 Flange		4	3 1/4	4	4	5	6	8	8 5/8			
	Class 300 Flange		4 1/4	3 1/2	4 5/16	4 7/16	5 5/16	6 1/2	8 1/2	9 5/16			
	Grooved		3 3/16	3 1/4	4	4 1/4	5	6	8	8 5/8			
Valve Stem Internal Thread		10-32	10-32	10-32	10-32	1/4-20	1/4-20	1/4-20	3/8-16	3/8-16	3/8-16	3/8-16	3/8-16
Stem Travel (in)		7/16	7/16	3/4	7/8	1	1 3/16	1 3/4	2 3/8	2 13/16	3 7/16	3 13/16	4 5/16
Approx. Wt. (lbs)		22	26	36	55	70	130	240	440	720	820	1200	1550

Reduced Port Main Valve Dimensions

DIM		VALVE SIZE INCHES (mm)				
		3" (80)	4" (100)	6" (150)	8" (200)	10" (250)
A	Class 150 Flange	10 1/4	14	17 3/4	21 7/16	26
	Class 300 Flange	11	14 1/2	18 11/16	22 7/16	27 7/16
B	Dia	6 3/4	9 3/16	11 11/16	15 3/4	20 1/8
C	Max	6 3/8	8 7/16	12 5/16	13 1/4	16 3/4
D	Class 150 Flange	3 3/4	4 1/2	5 1/2	6 3/4	8
	Class 300 Flange	4 1/8	5	6 1/4	7 1/2	8 3/4
E	NPT Body Tap	3/8	1/2	3/4	3/4	1
F	NPT Cvr. Plug Tap	3/8	1/2	3/4	3/4	1
G	NPT Cvr. Tap	3/8	1/2	3/4	3/4	1
Valve Stem Internal Thread		10-32	1/4-20	1/4-20	3/8-16	3/8-16
Stem Travel (in)		3/4	1	1 1/5	1 3/4	2 3/8
Approx. Wt. (Lbs)		35	80	140	275	480

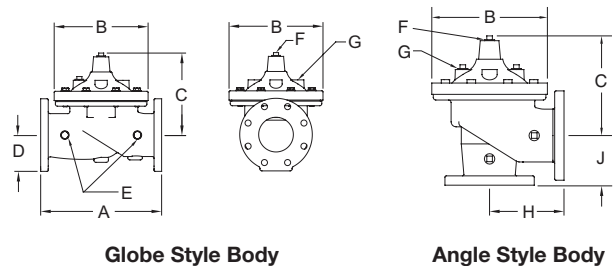

Globe Style Body

Angle Style Body

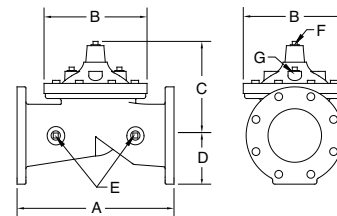

Reduced Port Body

Operation

The operation of the ZW207 begins with accurately sizing the valve, then fine tuning the control circuit by adjusting the pilot spring to the desired upstream pressure setting, which should be 10 to 15 psi higher than the setting of the upstream pressure reducing valve. The Zurn Wilkins Model ZW207 utilizes a pressure relief pilot valve which is installed on the inlet side of the control circuitry. The relief pilot is a normally closed, direct acting, spring loaded, diaphragm actuated valve. Inlet pressure is piped to the inlet port of the relief pilot. An internal sensing port connects inlet pressure to the relief pilot control chamber under the diaphragm. Thus, inlet pressure exceeding the preset acts to open the pilot while the adjustable spring seeks to keep it closed. High upstream pressure opens the pilot which will pressurize the cover of the control valve. Thus, the control valve will close. As long as the upstream pressure is above the set point of the pilot assembly, the main valve will stay in the closed position. It is recommended to connect the orifice fitting in the pilotry to a drain to allow water to discharge when the relief pilot opens.

Flow Characteristics

Full Port Globe and Angle Valve size	inches (mm)	1 1/4 (32)	1 1/2 (40)	2 (50)	2 1/2 (65)	3 (80)	4 (100)	6 (150)	8 (200)	10 (250)	12 (300)	14 (350)	16 (400)
Reduced Port Globe Valve Size	inches (mm)			3 (80)		4 (100)	6 (150)	8 (200)	10 (250)				
Suggested Flow (GPM)	Max. Continuous	27	37	62	88	135	235	535	925	1460	2075	2510	3275
Suggested Flow (Liters/sec)	Max. Continuous	1.7	2.3	3.9	5.5	9	15	34	58	92	130	158	206

Flow Characteristics

Suggested flow calculations are based on flow through Schedule 40 Pipe. Maximum continuous flow is approx. 6 ft/sec (1.8 meters/sec). Many factors should be considered in sizing valves including inlet pressure, outlet pressure and flow rates.

Typical Installation

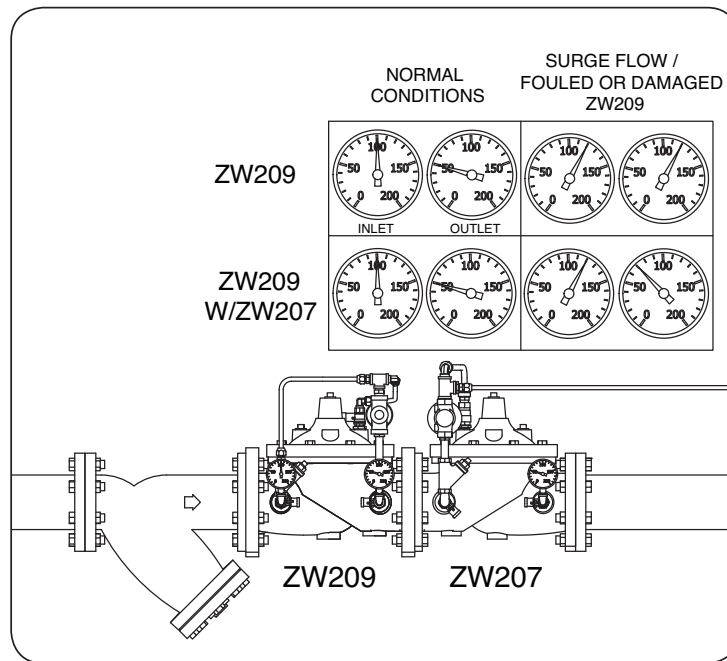

Specifications

The Excess Pressure Shutdown Valve shall be a diaphragm actuated, pilot controlled valve. The main valve body shall be ductile iron ASTM A 536. The stem of the basic valve shall be guided top and bottom. The diaphragm shall not be used as a seating surface. All internal and external ferrous surfaces shall be coated with a high quality, fusion epoxy coating. The pressure pilot control shall be field adjustable from 50 psi to 200 psi. The valve shall be certified to NSF/ANSI Standard 61. The Excess Pressure Shutdown Valve shall be a ZURN WILKINS Model ZW207.

Job Name _____ **Contractor** _____

Job Location _____ **Engineer** _____