

### Application

Ideal for use where Lead-Free\* valves are required. Designed for installation on potable water lines to reduce high inlet pressure to a lower outlet pressure. The high flow capacity makes this device most suitable for industrial water lines and commercial irrigation systems. The balanced piston design enables the regulator to react in a smooth and responsive manner to changes in system flow demand, while at the same time, providing protection from inlet pressure changes. Body is drilled, tapped and plugged to accept low flow by-pass (Model 34-NR3XLHRSCDUBPK).

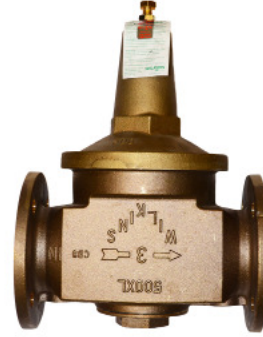

### Approvals

- Meets the requirements of NSF/ANSI 61\*  
\*(0.25% MAX. WEIGHTED AVERAGE LEAD CONTENT)

### Materials

Body & cover	Low Lead Cast bronze, ASTM B 806
Bell housing	Cast bronze, ASTM B 584
Stem & plunger	Low Lead Cast bronze, ASTM B 806
Seat	Stainless steel, 300 Series
Elastomers	EPDM (FDA approved) Buna nitrile (FDA approved)
Polymers	Delrin™

### Features

Sizes: 2", 2 1/2", 3"	300 psi
Maximum working water pressure	140° F
Maximum working water temperature	25 psi to 75 psi
Reduced pressure range	50 psi
Factory preset	ANSI Class 125
End connections (flanged)	

### Options

(Suffixes can be combined)

- 510XLFC- 400 psi inlet rating, 75 psi to 125 psi spring range, factory set at 85 psi
- FSC - with cast iron "Y" type flanged strainer, fusion epoxy coated, inside and out (2 1/2" & 3" only)
- HR - spring range is 75-125 psi, factory set at 85 psi
- HLR - spring range is 10-125 psi, factory set at 50 psi
- HTSTSC- high temperature application, up to 180° F
- LPV - high temperature application, up to 180° F spring range is 10-35 psi, factory set at 20 psi
- LPC - spring range is 10-35 psi, factory set at 20 psi
- SW - made for salt water service
- P - tapped and plugged for gauge
- G - tapped and plugged with gauge

### Accessories

- Repair kit (rubber only)
- Low Flow by-pass kit (34-NR3XLHRSCDUBPK)

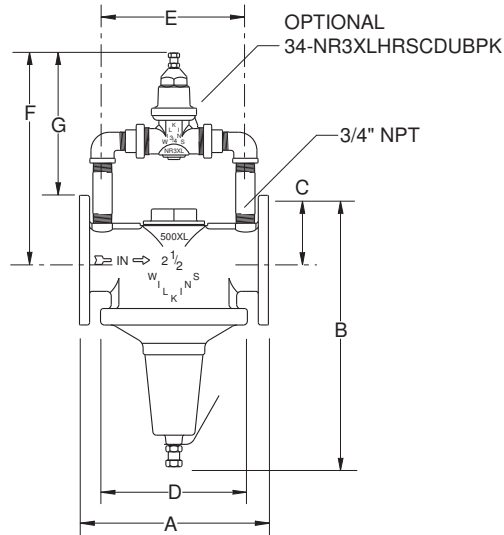

### Dimensions & Weights (do not include pkg.)

SIZE		CONNECTIONS	DIMENSIONS (approximate)														WEIGHT	
			A		B		C		D		E		F		G			
in.	mm		in.	mm	in.	mm	in.	mm	in.	mm	in.	mm	in.	mm	in.	mm	lbs.	kg.
2	50	FLANGED	10 3/8	263	15	381	3	76	6 1/2	165	7 25/32	198	11 1/2	292	8 1/2	216	30	13.5
2 1/2	65	FLANGED	10 3/8	263	15	381	3 1/2	89	8	203	7 25/32	198	11 1/2	292	8	203	30	13.5
3	80	FLANGED	11	279	17 3/4	451	3 3/4	95	8	203	7 25/32	198	12 3/64	306	8 5/16	211	50	22.5

## Flow Characteristics

### MODEL 500XLFCBP 2" THRU 3" (STANDARD & METRIC)

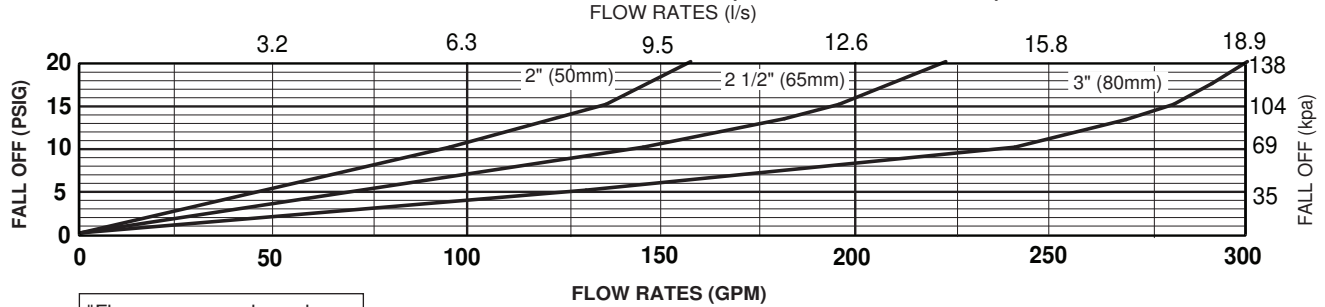

"Flow curves are based on a 50 psi pressure differential"

## Typical Installation

Local codes shall govern installation requirements. Unless otherwise specified, the assembly shall be installed in accordance with the manufacturers' instructions and the latest edition of the Uniform Plumbing Code. The assembly shall be installed with sufficient side clearance for testing and maintenance. The Model 500XLFCBP may be installed in any position. Multiple installations are recommended for wide demand variations or where the desired pressure reduction is more than 4 to 1 (ie: 200 psi inlet reduced to 50 psi outlet). **Caution:** Anytime a reducing valve is adjusted, a pressure gauge must be used downstream to verify correct pressure setting. Do not bottom adjustment bolt on bell housing.

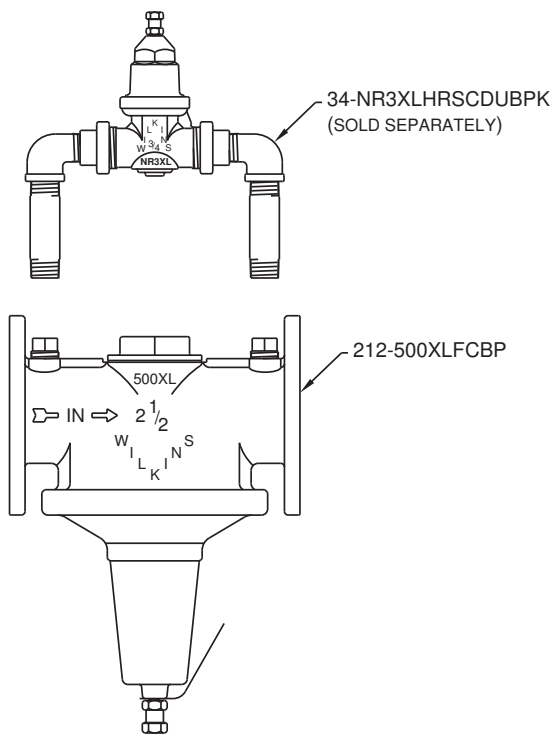

Parallel Installation

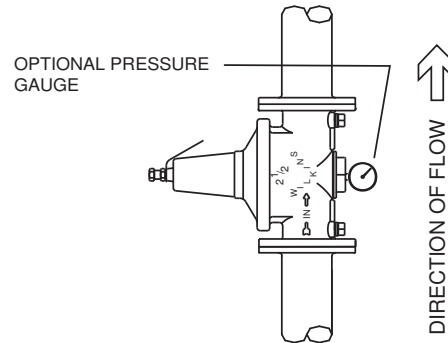

Vertical Installation

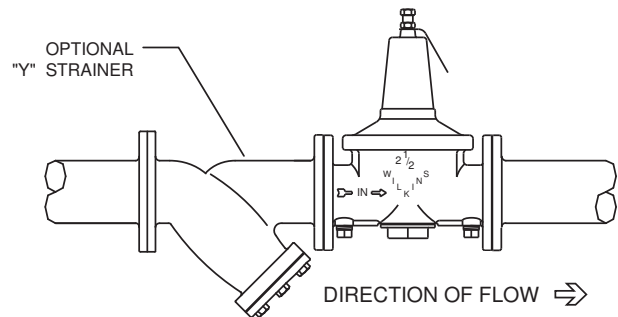

Horizontal Installation

## Specifications

The Pressure Reducing Valve shall be certified to NSF/ANSI 61, consist of a low-lead bronze body and bell housing with flanged connections, shall have a separate access cover for the plunger and shall have a bolt to adjust the downstream pressure. The assembly shall be of the balanced piston design and shall reduce pressure in both flow and no-flow conditions. The bronze bell housing and access cap shall be threaded to the body and shall not require the use of ferrous screws. The pressure reducing valve shall be tapped and plugged to accept a Model 34-NR3XLHRSCDUBPK low flow by-pass kit. The Pressure Reducing Valve shall be a ZURN WILKINS Model 500XLFCBP.